

BENEFITS WITH USING XAVITECH PUMP MOUNT

- Absorbs vibrations
- Easy mounting on PCB or other materials
- Electronic or other components can be placed underneath
- Cost effective

MOUNT DRAWING

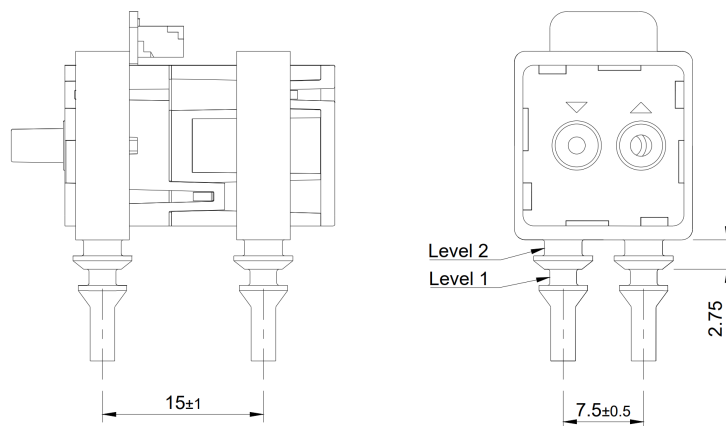

Drill hole, level 2: 3.5 mm

Drill hole, level 1: 3.0 mm

PUMP MOUNT FOR X100

Xavitech offers a solution that is based on molded parts in silicone material for pull through quick mount. By press fitting two soft holders, one from each side of the pump, you get 4 soft arrow like pins underneath the pump. These pins you can pull through holes and they will expand on the other side of a PCB and thus create a lock. There are two arrows on each pin so you can mount the pump at two different levels. At level 1 the pump will be elevated 2.75 mm and enables you to have electrical components underneath the pump. When pump is mounted on PCB, excessive parts of the pin underneath the PCB can be cut away.

Information furnished is believed to be accurate and reliable. However, Xavitech assumes no responsibility for the consequences of use of such information nor for any infringement of patents or other rights of third parties which may result from its use. No license is granted by implication or otherwise under any patent or patent rights of Xavitech. Specifications mentioned in this publication are subject to change without notice. This publication supersedes and replaces all information previously supplied. Xavitech products are not authorized for use as critical components in life support devices or systems without express written approval of Xavitech.

© 2025 Xavitech - All Rights Reserved
X100 Pump mount X3001001_2025-03-20

XAVITECH AB. INDUSTRIGATAN 17. 871 53. HÄRNÖSAND. SWEDEN. TELEPHONE +46 (0) 611 55 61 00. E-MAIL: XAVITECH@XAVITECH.COM